

Basic Microscopy: Laboratory Exercises

Introduction

After you have completed the Basic Microscopy eLearning course, it is strongly recommended that you complete the following laboratory exercises to transfer the didactic content of the course to experiential knowledge gained through hands-on laboratory exercises with your equipment in your laboratory. Your supervisor/mentor should work with you to develop these laboratory skills as well as confirm that these exercises have been completed. The number and types of exercises you will complete will be at the discretion of your supervisor/mentor based on procedures followed within your laboratory. Included in the laboratory exercises portion of this course are the objectives of the exercises as well as the prepared exercises. After the laboratory exercises are completed and discussed with your supervisor/mentor, your supervisor/mentor should then follow-up the exercises with instruction related to your laboratory's specific procedures or guidelines.

Laboratory Exercise Objectives

After completing the laboratory exercises, you will be able to:

1. Correctly identify various parts of a brightfield microscope.
2. Utilize the Köhler illumination procedure and job aid to correctly perform Köhler illumination on a brightfield microscope.
3. Apply focusing techniques for the 10X, 40X, and 100X objectives to achieve optimal field of view.
4. Use the 100X objective with oil immersion to detect and identify microscopic microorganisms.
5. Compute total magnification for the 40X high dry objective as well as other objectives.
6. Apply the calibration of the ocular micrometer procedure and job aid to correctly perform ocular micrometer calibration on a brightfield microscope.
7. Calculate size of a microorganism using the previously calculated ocular micrometer result.
8. List the make and model of the brightfield microscope used in your laboratory.
9. Describe where to find manufacturer's instructions for the brightfield microscope.
10. Demonstrate proper care, cleaning, and maintenance procedures for the brightfield microscope.
11. Summarize what, when, and where to document routine maintenance performed on the bright microscope for your laboratory records.

Note: Be sure to review the proper use of personal protective equipment (PPE) and laboratory equipment according to your laboratory's procedures and safety manual.

Laboratory Exercise I (continued)

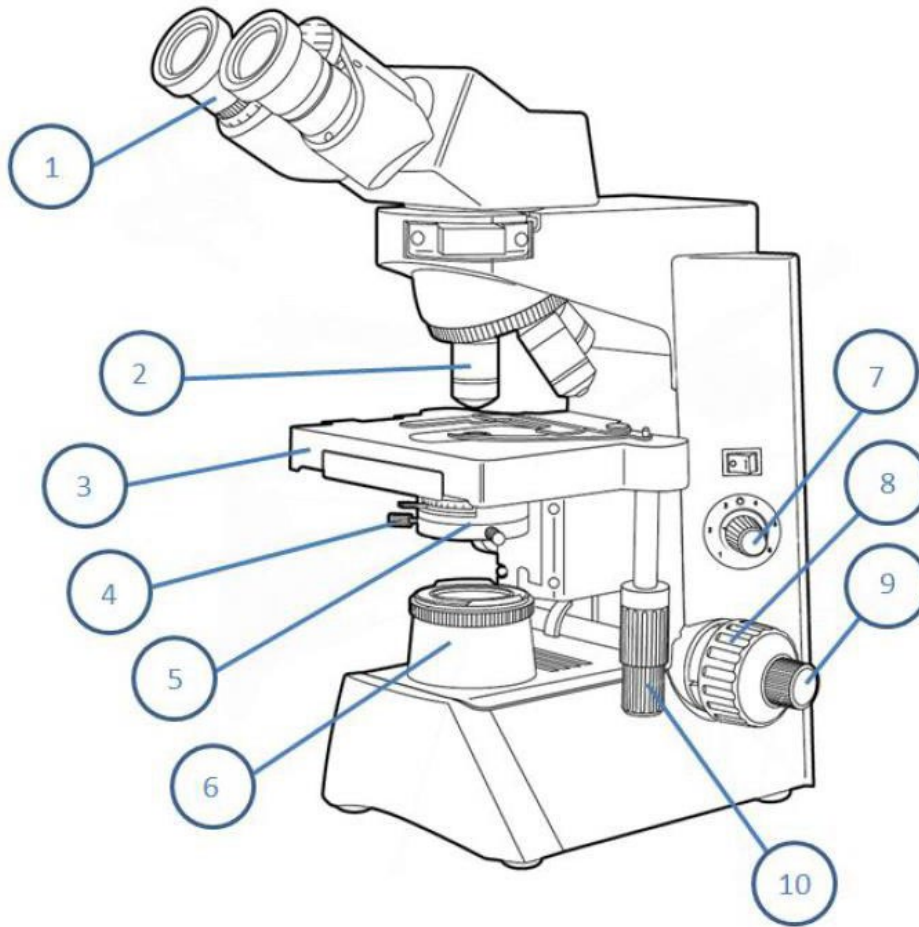

Word Bank

Centering Screws
Fine Adjustment
Condenser
Diaphragm Stage
Controls
Ocular
Light Source
Field Diaphragm
Objective
Coarse
Adjustment
Stage

1. _____
2. _____
3. _____
4. _____
5. _____
6. _____
7. _____
8. _____
9. _____
10. _____

