



Basic Microscopy Laboratory Exercises

Introduction

After you have completed the Basic Microscopy eLearning course, it is strongly recommended that you complete the following laboratory exercises to transfer the didactic content of the course to experiential knowledge gained through hands-on laboratory exercises with your equipment in your laboratory. Your supervisor/mentor should work with you to develop these laboratory skills as well as confirm that these exercises have been completed. The number and types of exercises you will complete will be at the discretion of your supervisor/mentor based on procedures followed within your laboratory. Included in the laboratory exercises portion of this course are the objectives of the exercises as well as the prepared exercises. After the laboratory exercises are completed and discussed with your supervisor/mentor, your supervisor/mentor should then follow-up the exercises with instruction related to your laboratory's specific procedures or guidelines.

Laboratory Exercise Objectives

After completing the laboratory exercises, you will be able to:

1. Correctly identify various parts of a brightfield microscope.
2. Utilize the Köhler illumination procedure and job aid to correctly perform Köhler illumination on a brightfield microscope.
3. Apply focusing techniques for the 10X, 40X, and 100X objectives to achieve optimal field of view.
4. Use the 100X objective with oil immersion to detect and identify microscopic microorganisms.
5. Compute total magnification for the 40X high dry objective as well as other objectives.
6. Apply the calibration of the ocular micrometer procedure and job aid to correctly perform ocular micrometer calibration on a brightfield microscope.
7. Calculate size of a microorganism using the previously calculated ocular micrometer result.
8. List the make and model of the brightfield microscope used in your laboratory.
9. Describe where to find manufacturer's instructions for the brightfield microscope.
10. Demonstrate proper care, cleaning, and maintenance procedures for the brightfield microscope.
11. Summarize what, when, and where to document routine maintenance performed on the bright microscope for your laboratory records.

Note: Be sure to review the proper use of personal protective equipment (PPE) and laboratory equipment according to your laboratory's procedures and safety manual.

Laboratory Exercise I

Objectives:

After completing this laboratory exercise, you will be able to:

1. Correctly identify various parts of a brightfield microscope.

Exercises:

1. Label the correct parts of a brightfield microscope on the graphic on the following page.
2. Identify the following parts of a brightfield microscope on the bench microscope you are using:
 - A. Objectives
 - B. Condenser (Iris) diaphragm
 - C. Coarse adjustment
 - D. Fine adjustment

Remember: You are able to use your Components of the Microscope job aid for this exercise.

Notes:

Mentor/Supervisor /Date

Laboratory Exercise I (continued)

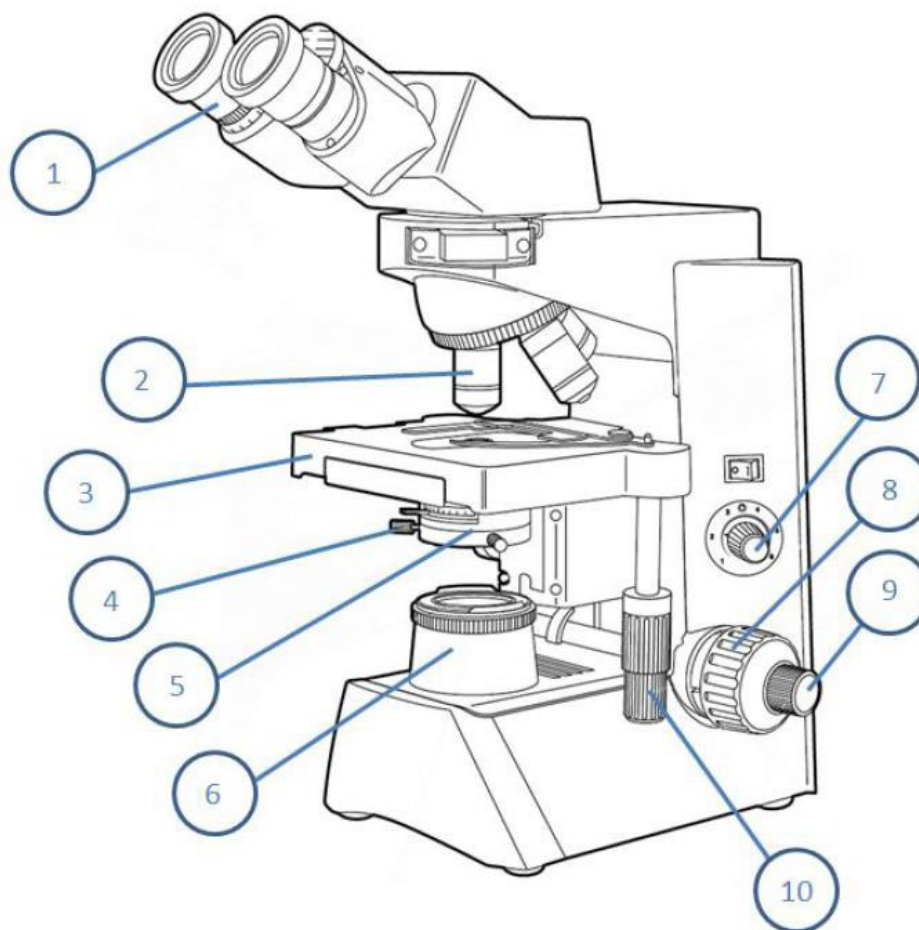

Word Bank

- Centering Screws
- Fine Adjustment
- Condenser Diaphragm
- Stage Controls
- Ocular
- Light Source
- Field Diaphragm
- Objective
- Coarse Adjustment
- Stage

1. _____
2. _____
3. _____
4. _____
5. _____
6. _____
7. _____
8. _____
9. _____
10. _____

Laboratory Exercise II

Objectives:

After completing this laboratory exercise, you will be able to:

1. Utilize the Köhler illumination procedure and job aid to correctly perform Köhler illumination on a brightfield microscope.

Exercise:

If your microscope has an adjustable field diaphragm, obtain optimal illumination using the Köhler illumination procedure.

Remember: You are able to use your Köhler Illumination job aid for this exercise.

Notes:

Mentor/Supervisor /Date

Laboratory Exercise III

Objectives:

After completing this laboratory exercise, you will be able to:

1. Apply focusing techniques for the 10X, 40X, and 100X objectives to achieve optimal field of view.
2. Use the 100X objective with oil immersion to detect and identify microscopic organisms.
3. Compute total magnification for the 40X high dry objective as well as other objectives.

Exercises:

1. Place a microscope slide (Gram stain, Giemsa stain, etc.) on the brightfield microscope stage and focus on the specimen using the 10x objective. Be sure to fully focus using the coarse and fine adjustment knobs. Now, move to the 40X objective and focus on the specimen. After the 10X and 40X examination has been completed, demonstrate how to look at a microscope slide using the 100X objective. Recall what is needed to complete the task and when to be cautious.
2. Calculate total magnification using your 40X high dry objective on your brightfield microscope.

Notes:

Mentor/Supervisor /Date

Laboratory Exercise IV

Objectives:

After completing this laboratory exercise, you will be able to:

1. Apply the calibration of the ocular micrometer procedure and job aid to correctly perform ocular micrometer calibration on a brightfield microscope.
2. Calculate size of a microorganism using the previously calculated ocular micrometer result.

Exercises:

1. Calibrate (or practice calibrating if your microscope is already calibrated) the objectives of a brightfield microscope using an ocular micrometer. Calibrate each objective. Remember: You are able to use your Ocular Micrometer Calibration job aid for this exercise.
2. If possible, obtain a microscope slide with an organism present. Measure the size of the organism using your new calibration factors.

Remember: You are able to use your Calibration of the Ocular Micrometer job aid for this exercise.

Notes:

Mentor/Supervisor /Date

Laboratory Exercise V

Objectives:

After completing this laboratory exercise, you will be able to:

1. List the make and model of the brightfield microscope used in your laboratory
2. Describe where to find manufacturer’s instructions for the brightfield microscope
3. Summarize what, when, and where to document routine maintenance performed on the bright microscope for your laboratory records.

Exercise:

1. Identify with the help of your supervisor/mentor the make and model of your brightfield microscope, where to find the manufacturer’s instructions, where to document any routine maintenance that is performed and how often your microscope should be maintained or cleaned professionally.

Notes:

Mentor/Supervisor /Date

